

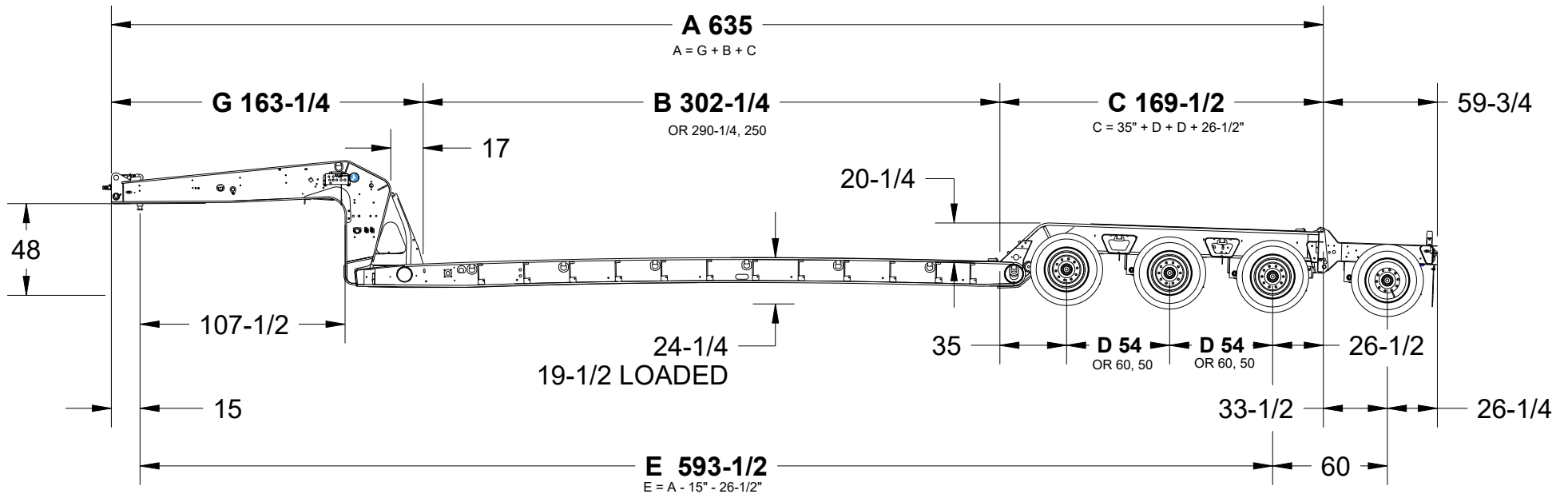

Model 860 Line Drawing



MODEL, # OF AXLES, AXLE SPREAD	A TOTAL LENGTH	G GOOSENECK (G/N)	B L/D BED LENGTH	C TRUNNION	D AXLE SPACING	E KING PIN TO REAR AXLE
860 3AX 54SPD	635 (52' 11")	163-1/4 (13' 7-1/4")	302-1/4 (25' 2-1/4")	169-1/2	54	593-1/2 (49' 5-1/2")
860 3AX 60SPD	635 (52' 11")	163-1/4 (13' 7-1/4")	290-1/4 (24' 2-1/4")	181-1/2	60	593-1/2 (49' 5-1/2")
860 3AX 50SPD	574-3/4 (47' 10-3/4")	163-1/4 (13' 7-1/4")	250 (20' 10")	161-1/2	50	533-1/4 (44' 5-1/4")

AX = AXLE
SPD = SPREAD

SHOWN

2022 / 04 / 27
PAGE 1
LD860

Disclaimer - Landoll has a corporate policy of continuous product improvement and development, therefore, specifications are subject to change without any advance notice. Landoll is not responsible for differences between the specifications or illustrations contained on literature, data sheets, website and actual equipment.

The information on any form of this website is intended only for the sole use of Landoll. We do not share or sell any of this information to third parties. This drawing and all information therein is property of Landoll and is confidential. It must not be made public or copied. This drawing is loaned subject to return upon demand and shall not be used directly or indirectly in anyway detrimental to our interest. Drawing illustrates standard equipment; optional equipment may change standard measurements.





Model 860 Line Drawing

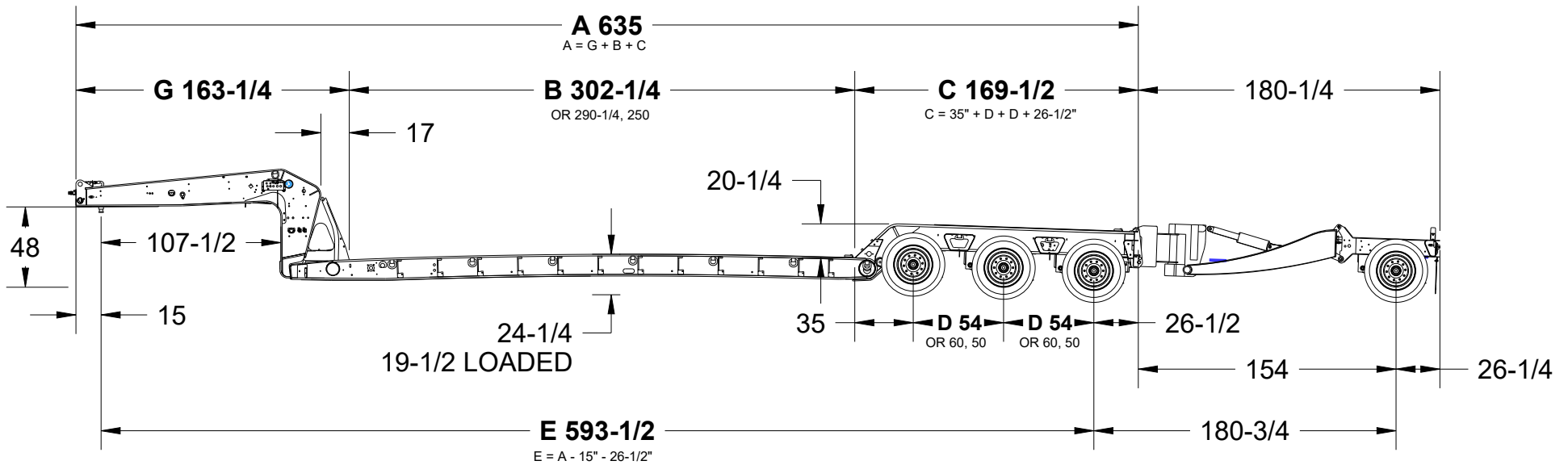

SPREADER WITH FLIP

MODEL, # OF AXLES, AXLE SPREAD	A TOTAL LENGTH	G GOOSENECK (G/N)	B L/D BED LENGTH	C TRUNNION	D AXLE SPACING	E KING PIN TO REAR AXLE
860 3AX 54SPD	635 (52' 11")	163-1/4 (13' 7-1/4")	302-1/4 (25' 2-1/4")	169-1/2	54	593-1/2 (49' 5-1/2")
860 3AX 60SPD	635 (52' 11")	163-1/4 (13' 7-1/4")	290-1/4 (24' 2-1/4")	181-1/2	60	593-1/2 (49' 5-1/2")
860 3AX 50SPD	574-3/4 (47' 10-3/4")	163-1/4 (13' 7-1/4")	250 (20' 10")	161-1/2	50	533-1/4 (44' 5-1/4")

AX = AXLE
SPD = SPREAD

SHOWN

2022 / 04 / 27
PAGE 2
LD860

Disclaimer - Landoll has a corporate policy of continuous product improvement and development, therefore, specifications are subject to change without any advance notice. Landoll is not responsible for differences between the specifications or illustrations contained on literature, data sheets, website and actual equipment.

The information on any form of this website is intended only for the sole use of Landoll. We do not share or sell any of this information to third parties. This drawing and all information therein is property of Landoll and is confidential. It must not be made public or copied. This drawing is loaned subject to return upon demand and shall not be used directly or indirectly in anyway detrimental to our interest. Drawing illustrates standard equipment; optional equipment may change standard measurements.

Landoll • Marysville, KS USA • 800-428-5655 • www.landoll.com

